

STOP BLOCKS CROWNED

CODE	L	A
ASC018	20	Drill & C/Bore for M8 Soc Hd Scr
ASC019	20	M8 x 1.25
ASC020	25	Drill & C/Bore for M10 Soc Hd Scr
ASC021	25	M10 x 1.5
ASC060	60	Drill & C/Bore for M10 Soc Hd Scr
ASC061	60	M10 x 1.5
ASC090	90	Drill & C/Bore for M10 Soc Hd Scr
ASC091	90	M10 x 1.5

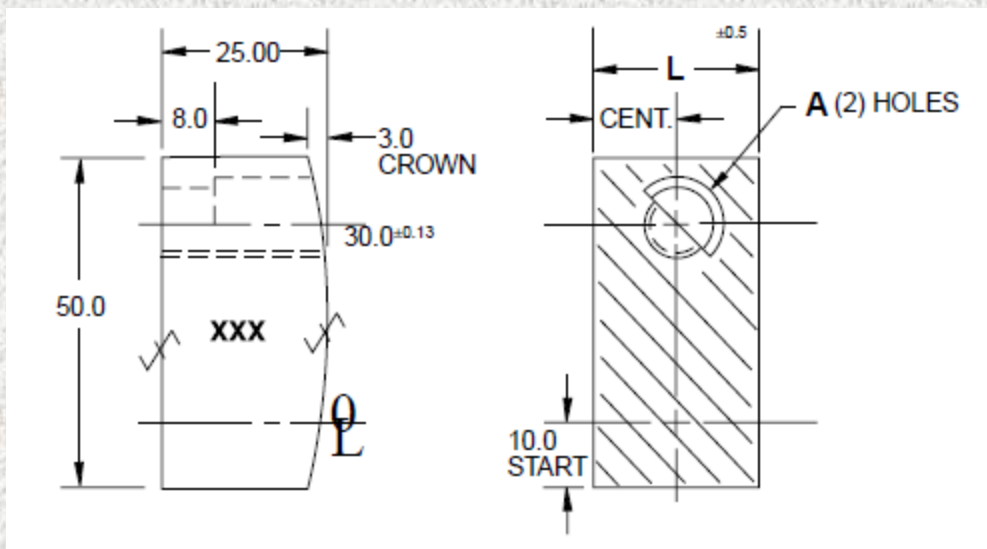

1. ESPECIFICACIONES .

- 1.1 SUPERFICIES PLANAS, PARALELAS Y PERPENDICULARES
CON UNA TOLERANCIA DE 0.015MM.
- 1.2 ACABADO EN LA SUPERFICIE : PAVONADO
- 1.3 IDENTIFICAR CON EL CODIGO DEL PRODUCTO

2. TOLERANCIAS DIMENCIONALES

1 DIGITO +- 0.3 2 DIGITOS +- 0.03 3 DIGITOS +-0.015

