

STOP BLOCKS FLAT

CODE	L	A
ASF018	20	Drill & C/Bore for M8 Soc Hd Scr
ASF019	20	M8 x 1.25
ASF020	25	Drill & C/Bore for M10 Soc Hd Scr
ASF021	25	M10 x 1.5
ASF060	60	Drill & C/Bore for M10 Soc Hd Scr
ASF061	60	M10 x 1.5
ASF090	90	Drill & C/Bore for M10 Soc Hd Scr
ASF091	90	M10 x 1.5

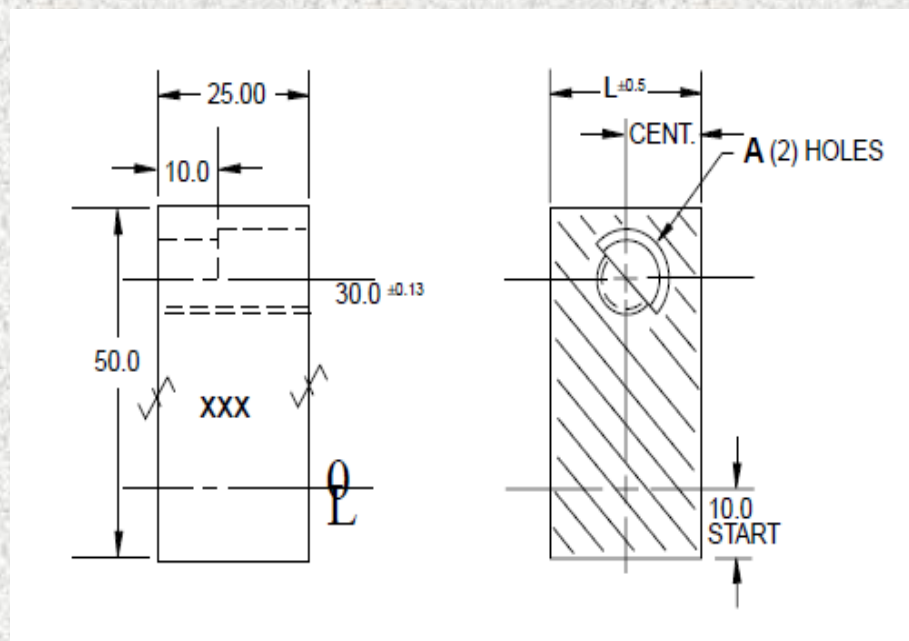

1. ESPECIFICACIONES .

1.1 SUPERFICIES PLANAS, PARALELAS Y PERPENDICULARES
CON UNA TOLERANCIA DE 0.015MM.

1.2 ACABADO EN LA SUPERFICIE : PAVONADO

1.3 IDENTIFICAR CON EL CODIGO DEL PRODUCTO

2. TOLERANCIAS DIMENSIONALES

1 DIGITO +- 0.3 2 DIGITOS +- 0.03 3 DIGITOS +-0.015